

Key Plant manufacture an extensive range of clamps and gripper chucks. There are various models which can be used to complement our range of welding positioners and head & tailstocks

**Specialised design can be produced to suit customer's components with internal and external tooling.**

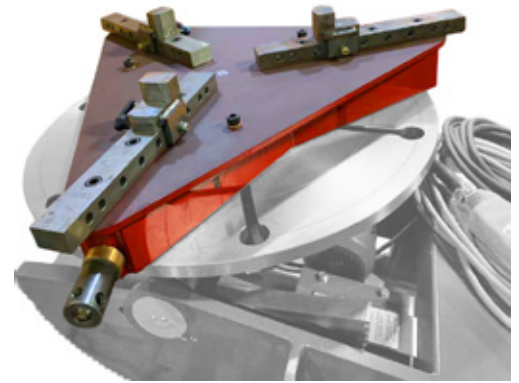

Part of the X3 Jaw Chuck machining process at our Key Plant Works, UK

### 3 Jaw Chuck - X3

Specification	Model: X324	Model: X336
Inside Range	5-1/2" to 31-1/4" (140mm to 794mm)	5-1/2" to 44-3/8" (140mm to 1127mm)
Outside Range	1-1/2" to 27-5/8" (38mm to 702mm)	1-1/2" to 40-3/4" (38mm to 1035mm)



### 3 Jaw Self Centering Chuck - WPSC

Specification				
Model	Diameter of the hole through the centre of chuck	Clamping Range Minimum	Clamping Range Maximum	Weight
WP-200	3.15" (80mm)	0.5" (13mm)	12" (300mm)	13lb (6kg)
WP-300	4" (102mm)	1.5" (38mm)	15" (390mm)	26.5lb (12kg)
WP-400	6.70" (170mm)	3.5" (89mm)	20" (510mm)	48.5lb (22kg)
WPS-600	14.25" (362mm)	17.75" (451mm)	41.50" (1054mm)	293lb (133kg)
WPS-1000	27.50" (699mm)	23.50" (604mm)	42.25" (1150mm)	518lb (235kg)

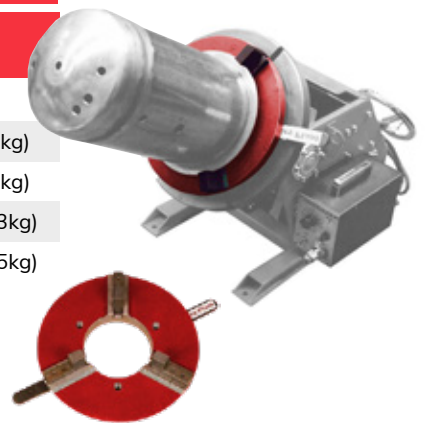

Key Plant's Self Centering Gripper Chucks are ideal for use for welding and providing higher levels of efficiency and versatility in operations involving welding of fittings, flanges, etc.

- Quickly & Easily Mounted on any make of positioner, turntable or tailstock using three bolts provided with gripper.
- Rugged Construction, light weight providing a bigger working load because of the low gravitational centre.
- Self Centering, fast, smooth close/open action using lever to firmly lock or release work piece.

Key Plant is a **global leader** in the **design and manufacture of weld automation equipment** and more.

We **Sell, Rent and Lease** our innovative welding and positioning equipment - **all over the world**.

We are **industry gamechangers**. Can't find what you require? or need a larger capacity? **Contact a Key Plant specialist today.**

Stay Connected.

